



CAMPEONATO RALLY ARGENTINO

DIRECTV

LIBRO DE RUTA



MAIN SPONSORS:



SPONSORS OFICIALES:



TODOS LOS DÍAS SALVO TIÉRDOS Y SABADOS

AUTO OFICIAL:



Símbolos Road Book			
	Control Horario		Atención, angosto
	Largada de prueba especial		Señal de celular
			Sin señal
	Final de prueba especial		Lomada sobre asfalto
			Lomada sobre tierra
	Stop		Vado con agua
			Vado seco
	Rescate Médico		Corte con agua
			Corte Seco
	Ingresa a Asfalto		Ingresa a Tierra
	Atención		Cartel rutero
	Peligro		Inicio doble circulación autos de carrera
	Peligro extremo		Fin doble circulación

Símbolos Road Book			
	Línea Doble = Asfalto		Línea fina = Tierra
	Alcantarilla <i>Drain</i>		Casas
	Puente <i>Bridge</i>		Escuela
	Guardagano		Iglesia o capilla
	Tranquera		Piedra
	Vías ferrocarril		Pirca
	Alambrado		Postes de electricidad
	Arbol		Refugio
	Cementerio		Estaciones de servicio

CH		PS CRUZ DEL EJE - PARQUE DE SERVICIO - SALIDA				PAGINA
CH		SH SHAKEDOWN				ETAPA
PRUEBAS ESPECIALES						SECCION
		DISTANCIA PE	ENLACE	DISTANCIA TOTAL	TIEMPO OTORGADO	PROMEDIO
			8,13	8,13	-	-
DISTANCIA		DIRECCION		INFORMACION	DISTANCIA REGRESIVA	
TOTAL	PARCIAL					
0,00	0,00			Salida Parque de Servicio G.P.S. 30 43.236s/64 48.333w	8,13	
0,10	0,10			(1) Reabastecimiento	8,03	
0,15	0,05			Por San Martín	7,98	
0,28	0,13				7,85	
0,36	0,08				7,77	
0,45	0,09			Por L. N. Alem	7,68	

CH		PS CRUZ DEL EJE - PARQUE DE SERVICIO - SALIDA				PAGINA
CH		SH SHAKEDOWN				ETAPA
PRUEBAS ESPECIALES						SECCION
		DISTANCIA PE	ENLACE	DISTANCIA TOTAL	TIEMPO OTORGADO	PROMEDIO
			8,13	8,13	-	-
DISTANCIA		DIRECCION		INFORMACION	DISTANCIA REGRESIVA	
TOTAL	PARCIAL					
0,72	0,27				7,41	
0,98	0,26				7,15	
1,51	0,53				6,62	
2,01	0,50				6,12	
2,48	0,47				5,65	
2,71	0,23			Por Av. Eva Perón	5,42	



CH		PS CRUZ DEL EJE - PARQUE DE SERVICIO - SALIDA				PAGINA
CH		SH SHAKEDOWN				ETAPA
PRUEBAS ESPECIALES						SECCION
		DISTANCIA PE	ENLACE	DISTANCIA TOTAL	TIEMPO OTORGADO	PROMEDIO
			8,13	8,13	-	-
DISTANCIA		DIRECCION		INFORMACION	DISTANCIA REGRESIVA	
TOTAL	PARCIAL					
2,85	0,14			YPF	5,28	
3,49	0,64			Por Vélez Sarsfield	4,64	
3,81	0,32				4,32	
3,90	0,09				4,23	
4,38	0,48				3,75	
5,00	0,62				3,13	

CH		PS CRUZ DEL EJE - PARQUE DE SERVICIO - SALIDA				PAGINA
CH		SH SHAKEDOWN				ETAPA
PRUEBAS ESPECIALES						SECCION
		DISTANCIA PE	ENLACE	DISTANCIA TOTAL	TIEMPO OTORGADO	PROMEDIO
			8,13	8,13	-	-
DISTANCIA		DIRECCION		INFORMACION	DISTANCIA REGRESIVA	
TOTAL	PARCIAL					
5,42	0,42				2,71	
6,35	0,93				1,78	
6,62	0,27				1,51	
7,15	0,53				0,98	
7,84	0,69				0,29	
8,13	0,29				0,00	

PASO 1º AUTO

CH	Sh	HORA	-	HORA	-
			30 45.645s/64 45.427w	Alt.:	506

! TIERRA

En árbol pintado con letra "M"

LPE	SH	SHAKEDOWN	PAGINA	VII		
CH	PS	CRUZ DEL EJE - PARQUE DE SERVICIO - INGRESO	DIA	-		
PRUEBAS ESPECIALES		SHAKEDOWN				
Sh		DISTANCIA PE	ENLACE	DISTANCIA TOTAL	TIEMPO OTORGADO	PROMEDIO
		1,39	9,36	10,75	-	-

LPE	SH	SHAKEDOWN	PAGINA	VIII		
CH	PS	CRUZ DEL EJE - PARQUE DE SERVICIO - INGRESO	DIA	-		
PRUEBAS ESPECIALES		SHAKEDOWN				
Sh		DISTANCIA PE	ENLACE	DISTANCIA TOTAL	TIEMPO OTORGADO	PROMEDIO
		1,39	9,36	10,75	-	-

DISTANCIA		DIRECCION	INFORMACION	DISTANCIA REGRESIVA
TOTAL	PARCIAL			
0,00	0,00	 1,39	PASO 1° AUTO Sh - - - <small>30 45.637s/64 45.417w Alt.: 506</small> En árbol pintado con letra "B"	10,75
0,37	0,37	 1,02		10,38
0,73	0,36	 0,66		10,02
1,10	0,37	 0,29	i ! PAVIMENTO	9,65
1,22	0,12	 0,17	SALE DE CAMINO	9,53
1,39	0,17	 0,00	FPE Sh - - - <small>30 45.667s/64 45.252w Alt.: 520</small> En poste pintado con letra "B"	9,36



LPE	SH	SHAKEDOWN	PAGINA IX			
CH	PS	CRUZ DEL EJE - PARQUE DE SERVICIO - INGRESO	DIA -			
PRUEBAS ESPECIALES		SHAKEDOWN			SECCION -	
Sh		DISTANCIA PE	ENLACE	DISTANCIA TOTAL	TIEMPO OTORGADO	PROMEDIO
		1,39	9,36	10,75	-	-
DISTANCIA		DIRECCION		INFORMACION	DISTANCIA REGRESIVA	
TOTAL	PARCIAL					
1,59	0,20			STOP G.P.S. 30 45.760s / 64 45.242w En poste eléctrico pintado con letra "M"	9,16	
2,16	0,57			(1) hacia P. de SERVICIO (2) hacia LPE SH	8,59	
6,04	3,88			Por Félix Cáceres	4,71	
6,14	0,10			Por Tomás Edison	4,61	
6,26	0,12			Por Sarmiento	4,49	
6,97	0,71			Por RUTA 38	3,78	

LPE	SH	SHAKEDOWN	PAGINA X			
CH	PS	CRUZ DEL EJE - PARQUE DE SERVICIO - INGRESO	DIA -			
PRUEBAS ESPECIALES		SHAKEDOWN			SECCION -	
Sh		DISTANCIA PE	ENLACE	DISTANCIA TOTAL	TIEMPO OTORGADO	PROMEDIO
		1,39	9,36	10,75	-	-
DISTANCIA		DIRECCION		INFORMACION	DISTANCIA REGRESIVA	
TOTAL	PARCIAL					
7,36	0,39			Por Juan XXI	3,39	
8,28	0,92				2,47	
8,58	0,30				2,17	
8,68	0,10				2,07	
8,78	0,10				1,97	
8,87	0,09				1,88	

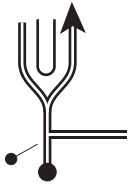
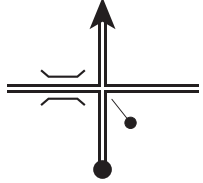
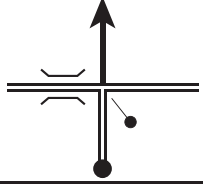
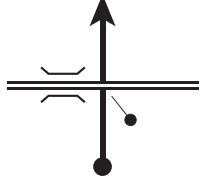
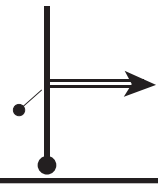
LPE	SH	SHAKEDOWN	PAGINA		XI		
CH	PS	CRUZ DEL EJE - PARQUE DE SERVICIO - INGRESO	DIA		-		
PRUEBAS ESPECIALES		SHAKEDOWN				SECCION	-
Sh		DISTANCIA PE	ENLACE	DISTANCIA TOTAL	TIEMPO OTORGADO	PROMEDIO	
		1,39	9,36	10,75	-	-	
DISTANCIA		DIRECCION		INFORMACION	DISTANCIA REGRESIVA		
TOTAL	PARCIAL						
9,09	0,22				1,66		
9,14	0,05				1,61		
9,61	0,47				1,14		
9,72	0,11			<i>i</i> ! TIERRA	1,03		
9,93	0,21				0,82		
10,03	0,10			<i>i</i> ! PAVIMENTO Por Gral. Paz	0,72		

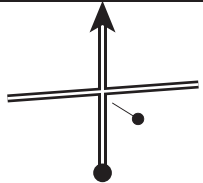
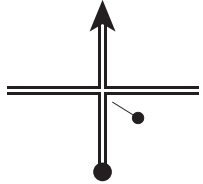
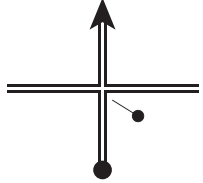
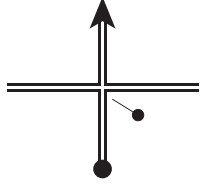
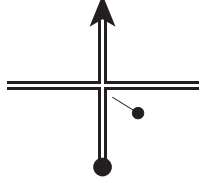
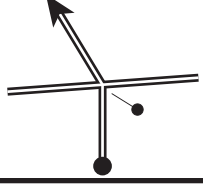

LPE	SH	SHAKEDOWN	PAGINA		XII		
CH	PS	CRUZ DEL EJE - PARQUE DE SERVICIO - INGRESO	DIA		-		
PRUEBAS ESPECIALES		SHAKEDOWN				SECCION	-
Sh		DISTANCIA PE	ENLACE	DISTANCIA TOTAL	TIEMPO OTORGADO	PROMEDIO	
		1,39	9,36	10,75	-	-	
DISTANCIA		DIRECCION		INFORMACION	DISTANCIA REGRESIVA		
TOTAL	PARCIAL						
10,14	0,11				0,61		
10,32	0,18				0,43		
10,40	0,08				0,35		
10,52	0,12				0,23		
10,63	0,11				0,12		
10,69	0,06				0,06		



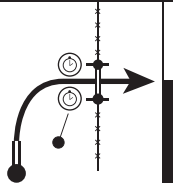



LPE	SH	SHAKEDOWN				PAGINA	XIII
	CH	PS	CRUZ DEL EJE - PARQUE DE SERVICIO - INGRESO				DIA
PRUEBAS ESPECIALES		SHAKEDOWN				SECCION	-
Sh		DISTANCIA PE	ENLACE	DISTANCIA TOTAL	TIEMPO OTORGADO	PROMEDIO	
		1,39	9,36	10,75	-	-	
DISTANCIA		DIRECCION		INFORMACION		DISTANCIA REGRESIVA	
TOTAL	PARCIAL						
10,75	0,06			<i>i!</i> TIERRA PREDIO DEL OLIVO Ingreso Parque de Servicio G.P.S. (30 43.165s/64 48.354w)		0,00	

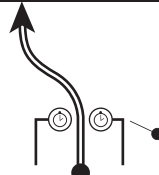

1ra Fecha

1 y 2 etapa

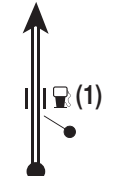
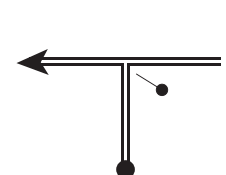
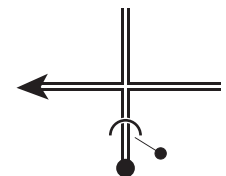

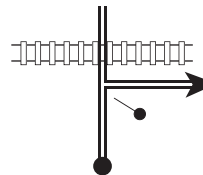
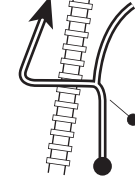
CH	0		CRUZ DEL EJE - PARQUE DE SERVICIOS - SALIDA		PAGINA
	3e		CRUZ DEL EJE - PARQUE CERRADO - SALIDA		1
CH	1/4		TUCLAME		ETAPA
					1/2
PRUEBAS ESPECIALES					
DISTANCIA PE		ENLACE	DISTANCIA TOTAL	TIEMPO OTORGADO	PROMEDIO
		54,46	54,46	1:00	54,46
DISTANCIA		DIRECCION	INFORMACION	DISTANCIA REGRESIVA	
TOTAL	PARCIAL				
0,00	0,00		 PASO 1° AUTO HORA 0 7:00 3e 15:00 CH (30 43.236s/64 48.333w) Alt.: 464 PREDIO DEL OLIVO CH 0 -Salida Parque de Servicios CH 3e -Salida Parque Cerrado	54,46	
			(1) Reabastecimiento	54,36	
0,15	0,05		Por San Martín	54,31	
0,28	0,13			54,18	
0,36	0,08			54,10	
0,45	0,09		Por L. N. Alem	54,01	

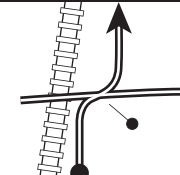
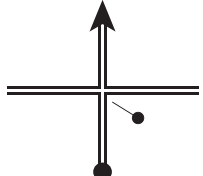
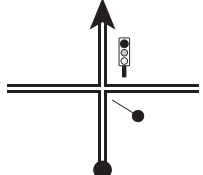
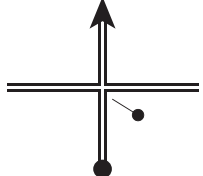
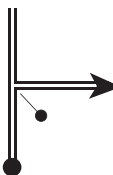
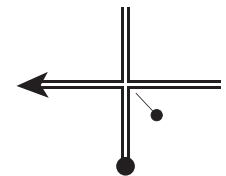
CH	0		CRUZ DEL EJE - PARQUE DE SERVICIOS - SALIDA		PAGINA
	3e		CRUZ DEL EJE - PARQUE CERRADO - SALIDA		2
CH	1/4		TUCLAME		ETAPA
					1/2
PRUEBAS ESPECIALES					
DISTANCIA PE		ENLACE	DISTANCIA TOTAL	TIEMPO OTORGADO	PROMEDIO
		54,46	54,46	1:00	54,46
DISTANCIA		DIRECCION	INFORMACION	DISTANCIA REGRESIVA	
TOTAL	PARCIAL				
0,72	0,27			53,74	
0,98	0,26			53,48	
1,51	0,53			52,95	
2,01	0,50			52,45	
2,48	0,47			51,98	
2,71	0,23		Por Av. Eva Perón	51,75	



CH	0		CRUZ DEL EJE - PARQUE DE SERVICIOS - SALIDA		PAGINA	
	3e		CRUZ DEL EJE - PARQUE CERRADO - SALIDA		3	
CH	1/4		TUCLAME		ETAPA	
					1/2	
PRUEBAS ESPECIALES					SECCION	
					1/2	
		DISTANCIA PE	ENLACE	DISTANCIA TOTAL	TIEMPO OTORGADO	PROMEDIO
			54,46	54,46	1:00	54,46
DISTANCIA		DIRECCION		INFORMACION	DISTANCIA REGRESIVA	
TOTAL	PARCIAL					
2,85	0,14	13		YPF	51,61	
				Por RUTA		
3,04	0,19	14			51,42	
3,44	0,40	15			51,02	
24,05	20,61	16		AXION	30,41	
25,17	1,12	17			29,29	
26,02	0,85	18			28,44	

CH	0		CRUZ DEL EJE - PARQUE DE SERVICIOS - SALIDA		PAGINA	
	3e		CRUZ DEL EJE - PARQUE CERRADO - SALIDA		4	
CH	1/4		TUCLAME		ETAPA	
					1/2	
PRUEBAS ESPECIALES					SECCION	
					1/2	
		DISTANCIA PE	ENLACE	DISTANCIA TOTAL	TIEMPO OTORGADO	PROMEDIO
			54,46	54,46	1:00	54,46
DISTANCIA		DIRECCION		INFORMACION	DISTANCIA REGRESIVA	
TOTAL	PARCIAL					
26,63	0,61	19			27,83	
26,81	0,18	20		YPF	27,65	
27,56	0,75	21			26,90	
38,63	11,07	22			15,83	
50,86	12,23	23			3,60	
53,62	2,76	24		!! CRUCE RUTA 	0,84	





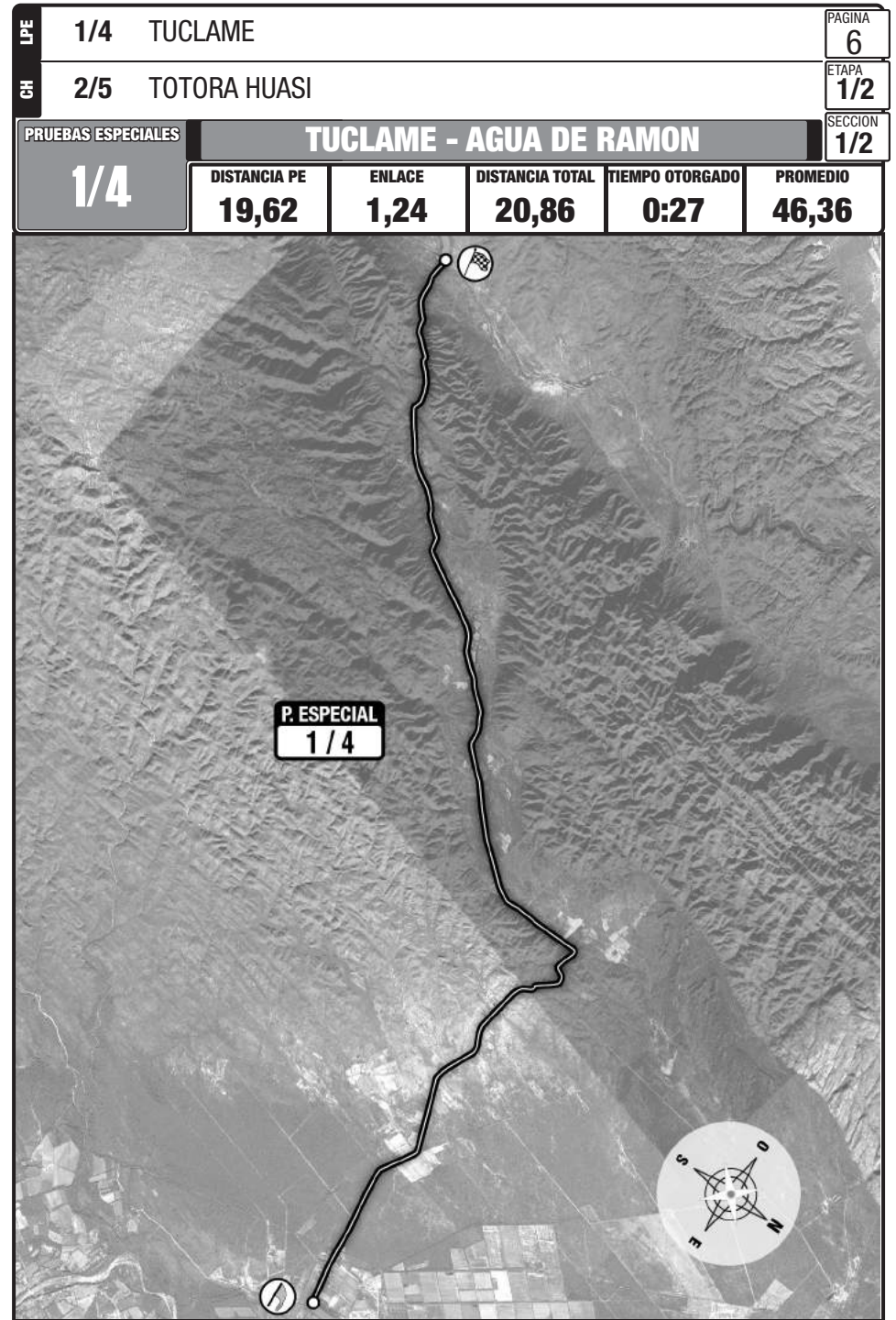



CH	0	CRUZ DEL EJE - PARQUE DE SERVICIOS - SALIDA	PAGINA		5														
	3e	CRUZ DEL EJE - PARQUE CERRADO - SALIDA	ETAPA		1/2														
CH	1/4	TUCLAME	SECCION		1/2														
PRUEBAS ESPECIALES			DISTANCIA PE	ENLACE	DISTANCIA TOTAL	TIEMPO OTORGADO	PROMEDIO												
				54,46	54,46	1:00	54,46												
DISTANCIA		DIRECCION	INFORMACION	DISTANCIA REGRESIVA															
TOTAL	PARCIAL																		
53,75	0,13			0,71															
54,04	0,29			0,42															
54,46	0,42		<table border="1"> <tr> <td colspan="4">PASO 1° AUTO</td> </tr> <tr> <td>1</td> <td>8:00</td> <td>4</td> <td>16:00</td> </tr> <tr> <td>CH</td> <td colspan="2">(30 45.266s/65 13.904w)</td> <td>Alt.: 392</td> </tr> </table> <p>En árbol pintado con letra "M" </p>	PASO 1° AUTO				1	8:00	4	16:00	CH	(30 45.266s/65 13.904w)		Alt.: 392	0,00			
PASO 1° AUTO																			
1	8:00	4	16:00																
CH	(30 45.266s/65 13.904w)		Alt.: 392																

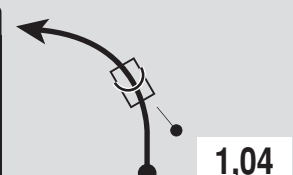

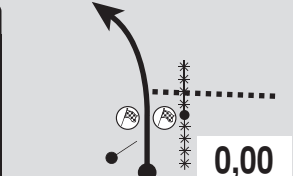
LPE	1/4	TUCLAME	PAGINA		7		
CH	2/5	TOTORA HUASI	ETAPA		1/2		
PRUEBAS ESPECIALES		TUCLAME - AGUA DE RAMON				SECCION	1/2
1/4		DISTANCIA PE	19,62	ENLACE	1,24	DISTANCIA TOTAL	20,86
		TIEMPO OTORGADO	0:27	PROMEDIO	46,36		
DISTANCIA		DIRECCION		INFORMACION		DISTANCIA REGRESIVA	
TOTAL	PARCIAL						
0,00	0,00			PASO 1° AUTO LPE 1 HORA 8:03 HORA 4 HORA 16:03 (30 45.296s/65 13.944w / Alt.: 388) En árbol pintado con letra "B"		20,86	
0,73	0,73					20,13	
4,96	4,23					15,90	
5,79	0,83					15,07	
10,95	5,16					9,91	
11,61	0,66					9,25	

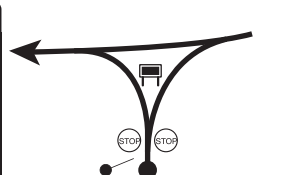
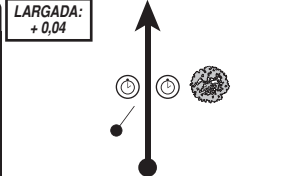
LPE	1/4	TUCLAME	PAGINA		8		
CH	2/5	TOTORA HUASI	ETAPA		1/2		
PRUEBAS ESPECIALES		TUCLAME - AGUA DE RAMON				SECCION	1/2
1/4		DISTANCIA PE	19,62	ENLACE	1,24	DISTANCIA TOTAL	20,86
		TIEMPO OTORGADO	0:27	PROMEDIO	46,36		
DISTANCIA		DIRECCION		INFORMACION		DISTANCIA REGRESIVA	
TOTAL	PARCIAL						
12,24	0,63					8,62	
12,61	0,37					8,25	
14,80	2,19					6,06	
15,59	0,79					5,27	
16,24	0,65					4,62	
17,95	1,71					2,91	

LPE	1/4	TUCLAME	PAGINA	9		
CH	2/5	TOTORA HUASI	ETAPA	1/2		
PRUEBAS ESPECIALES		TUCLAME - AGUA DE RAMON			SECCION	1/2
1/4		DISTANCIA PE	ENLACE	DISTANCIA TOTAL	TIEMPO OTORGADO	PROMEDIO
		19,62	1,24	20,86	0:27	46,36
DISTANCIA		DIRECCION		INFORMACION	DISTANCIA REGRESIVA	
TOTAL	PARCIAL					
18,58	0,63				2,28	
19,62	1,04			 1 4  FPE (30 50.967s/65 21.769w) Alt.: 452	1,24	
19,88	0,26			STOP En Cruce G.P.S. (30 51.047s / 65 21.897w) TOTORA HUASI	0,98	
20,86	0,98			 PASO 1° AUTO HORA 2 8:30 5 16:30 CH (30 51.420s/65 22.019w) Alt.: 453	0,00	

LPE	2/5	TOTORA HUASI	PAGINA	10		
CH	3/6	RUMI HUASI	ETAPA	1/2		
PRUEBAS ESPECIALES		TOTORA HUASI - LA PLAYA			SECCION	1/2
2/5		DISTANCIA PE	ENLACE	DISTANCIA TOTAL	TIEMPO OTORGADO	PROMEDIO
		18,66	29,96	48,62	1:00	48,62

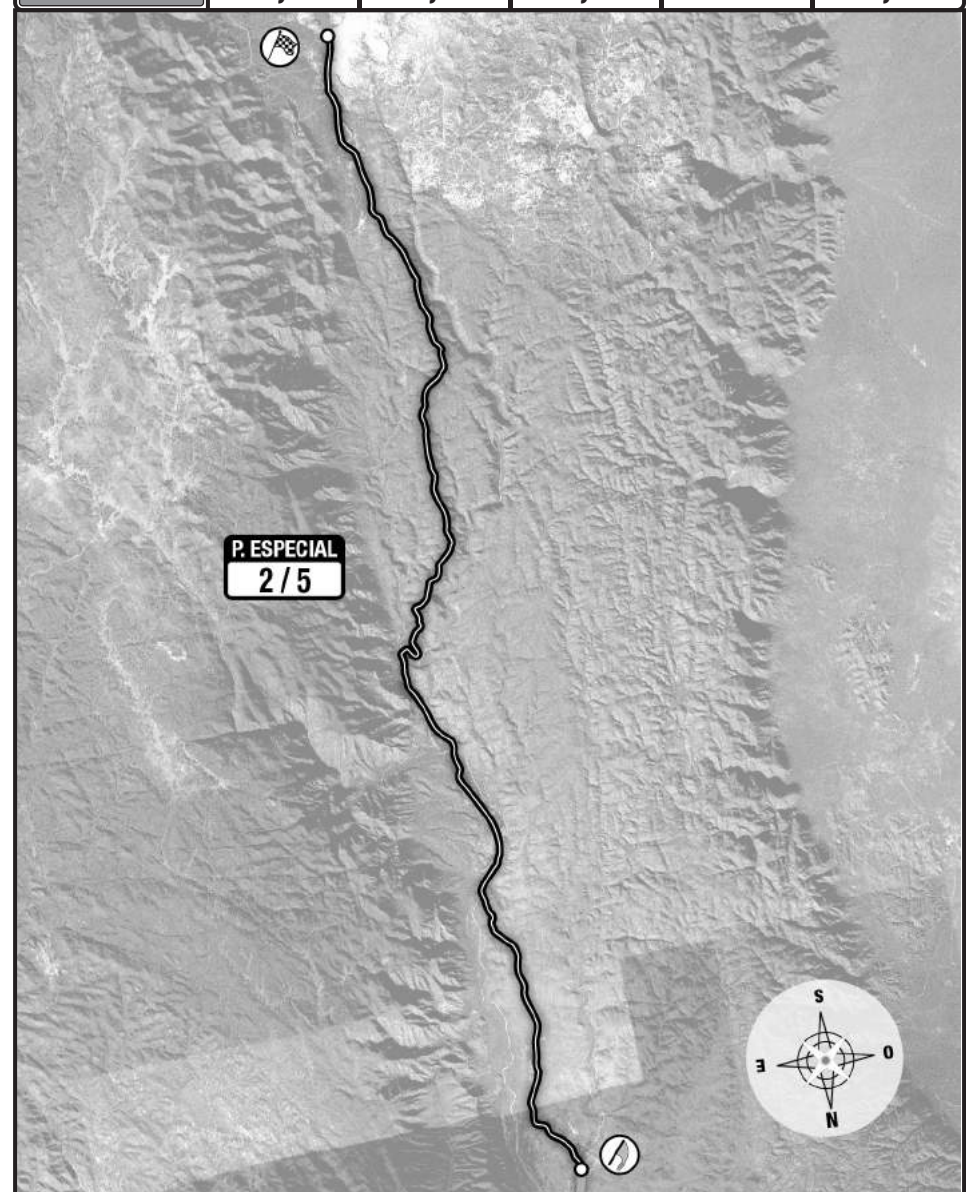

LPE	2/5	TOTORA HUASI	PAGINA 11			
CH	3/6	RUMI HUASI	ETAPA 1/2			
PRUEBAS ESPECIALES		TOTORA HUASI - LA PLAYA				
2/5		DISTANCIA PE	ENLACE	DISTANCIA TOTAL	TIEMPO OTORGADO	PROMEDIO
		18,66	29,96	48,62	1:00	48,62
DISTANCIA		DIRECCION		INFORMACION	DISTANCIA REGRESIVA	
TOTAL	PARCIAL					
0,00	0,00			<p>PASO 1° AUTO LPE 2 8:33 5 16:33 (30 51.444s/65 22.025w Alt.: 453)</p> <p>En poste de electricidad pintado con letra "B2021"</p>	48,62	
4,58	4,58				44,04	
4,99	0,41				43,63	
6,86	1,87				41,76	
7,40	0,54				41,22	
8,10	0,70				40,52	

LPE	2/5	TOTORA HUASI	PAGINA 12			
CH	3/6	RUMI HUASI	ETAPA 1/2			
PRUEBAS ESPECIALES		TOTORA HUASI - LA PLAYA				
2/5		DISTANCIA PE	ENLACE	DISTANCIA TOTAL	TIEMPO OTORGADO	PROMEDIO
		18,66	29,96	48,62	1:00	48,62
DISTANCIA		DIRECCION		INFORMACION	DISTANCIA REGRESIVA	
TOTAL	PARCIAL					
17,97	9,87				30,65	
18,30	0,33				30,32	
18,66	0,36			<p>FPE 2 5 (31 00.297s/65 21.787w Alt.: 799)</p> <p>En piedra pintada con letra "B"</p>	29,96	
18,95	0,29			<p>STOP G.P.S. (31 00.445s / 65 21.778w)</p> <p>En poste de electricidad pintado con letra "M"</p>	29,67	
19,92	0,97			<p>(1) Reabastecimiento G.P.S. (31 00.932s/64 21.730w)</p>	28,70	
27,09	7,17				21,53	



LPE	2/5	TOTORA HUASI	PAGINA 13			
CH	3/6	RUMI HUASI	ETAPA 1/2			
PRUEBAS ESPECIALES		TOTORA HUASI - LA PLAYA			SECCION 1/2	
2/5		DISTANCIA PE 18,66	ENLACE 29,96	DISTANCIA TOTAL 48,62	TIEMPO OTORGADO 1:00	PROMEDIO 48,62
DISTANCIA		DIRECCION		INFORMACION	DISTANCIA REGRESIVA	
TOTAL	PARCIAL					
27,24	0,15				21,38	
27,44	0,20				21,18	
30,75	3,31				17,87	
40,52	9,77			Por Maestro Pedro Aparicio	8,10	
40,64	0,12			Por Fundador Gregorio de Pedraza	7,98	
40,77	0,13				7,85	



LPE	2/5	TOTORA HUASI	PAGINA 14										
CH	3/6	RUMI HUASI	ETAPA 1/2										
PRUEBAS ESPECIALES		TOTORA HUASI - LA PLAYA			SECCION 1/2								
2/5		DISTANCIA PE 18,66	ENLACE 29,96	DISTANCIA TOTAL 48,62	TIEMPO OTORGADO 1:00	PROMEDIO 48,62							
DISTANCIA		DIRECCION		INFORMACION	DISTANCIA REGRESIVA								
TOTAL	PARCIAL												
40,87	0,10				7,75								
41,04	0,17			Por Boulevard	7,58								
47,80	6,76				0,82								
48,62	0,82			<p>LARGADA: +0,03</p> <p>PASO 1° AUTO</p> <table border="1"> <tr> <td>3</td> <td>9:33</td> <td>6</td> <td>17:33</td> </tr> <tr> <td colspan="2">HORA</td> <td colspan="2">HORA</td> </tr> </table> <p>31 02.054s/65 13.044w Alt.: 764</p> <p>En árbol pintado con letra "M" </p> <p>(1) Parada Colectivo</p>	3	9:33	6	17:33	HORA		HORA		0,00
3	9:33	6	17:33										
HORA		HORA											

LPE	3/6	RUMI HUASI	PAGINA		15	
	3a	CRUZ DEL EJE - ZONA TECNICA - INGRESO	ETAPA		1/2	
CH	6a	CRUZ DEL EJE - PARQUE CERRADO - INGRESO	SECCION		1/2	
PRUEBAS ESPECIALES		RUMI HUASI - RARA FORTUNA				
3/6		DISTANCIA PE	ENLACE	DISTANCIA TOTAL	TIEMPO OTORGADO	PROMEDIO
		18,27	51,03	69,30	1:15	55,44

LPE	3/6	RUMI HUASI	PAGINA		16	
	3a	CRUZ DEL EJE - ZONA TECNICA - INGRESO	ETAPA		1/2	
CH	6a	CRUZ DEL EJE - PARQUE CERRADO - INGRESO	SECCION		1/2	
PRUEBAS ESPECIALES		RUMI HUASI - RARA FORTUNA				
3/6		DISTANCIA PE	ENLACE	DISTANCIA TOTAL	TIEMPO OTORGADO	PROMEDIO
		18,27	51,03	69,30	1:15	55,44

DISTANCIA		DIRECCION	INFORMACION	DISTANCIA REGRESIVA
TOTAL	PARCIAL			
0,00	0,00	1 	 PASO 1° AUTO HORA 3 9:36 HORA 6 17:36 <small>(31 02.034s/65 13.049w / Alt.: 763)</small> En cactus pintado con letra "B"	69,30
2,14	2,14	2 		67,16
2,50	0,36	3 		66,80
3,00	0,50	4 		66,30
7,47	4,47	5 		61,83
8,50	1,03	6 		60,80



LPE	3/6	RUMI HUASI	PAGINA		17	
	CH	3a	CRUZ DEL EJE - ZONA TECNICA - INGRESO	ETAPA		1/2
6a		CRUZ DEL EJE - PARQUE CERRADO - INGRESO	SECCION		1/2	
PRUEBAS ESPECIALES			RUMI HUASI - RARA FORTUNA			
3/6		DISTANCIA PE	ENLACE	DISTANCIA TOTAL	TIEMPO OTORGADO	PROMEDIO
		18,27	51,03	69,30	1:15	55,44
DISTANCIA		DIRECCION		INFORMACION	DISTANCIA REGRESIVA	
TOTAL	PARCIAL					
8,64	0,14				60,66	
10,41	1,77				58,89	
12,86	2,45				56,44	
13,02	0,16				56,28	
14,42	1,40				54,88	
15,52	1,10				53,78	

LPE	3/6	RUMI HUASI	PAGINA		18	
	CH	3a	CRUZ DEL EJE - ZONA TECNICA - INGRESO	ETAPA		1/2
6a		CRUZ DEL EJE - PARQUE CERRADO - INGRESO	SECCION		1/2	
PRUEBAS ESPECIALES			RUMI HUASI - RARA FORTUNA			
3/6		DISTANCIA PE	ENLACE	DISTANCIA TOTAL	TIEMPO OTORGADO	PROMEDIO
		18,27	51,03	69,30	1:15	55,44
DISTANCIA		DIRECCION		INFORMACION	DISTANCIA REGRESIVA	
TOTAL	PARCIAL					
16,39	0,87				52,91	
18,27	1,88			En árbol pintado con letra "B"	51,03	
18,63	0,36			En cruce	50,67	
20,30	1,67				49,00	
21,56	1,26				47,74	
21,75	0,19				47,55	



LPE	3/6	RUMI HUASI	PAGINA	19		
CH	3a	CRUZ DEL EJE - ZONA TECNICA - INGRESO	ETAPA	1/2		
	6a	CRUZ DEL EJE - PARQUE CERRADO - INGRESO	SECCION	1/2		
PRUEBAS ESPECIALES		RUMI HUASI - RARA FORTUNA				
3/6		DISTANCIA PE	ENLACE	DISTANCIA TOTAL	TIEMPO OTORGADO	PROMEDIO
		18,27	51,03	69,30	1:15	55,44
DISTANCIA		DIRECCION		INFORMACION	DISTANCIA REGRESIVA	
TOTAL	PARCIAL					
21,89	0,14			i ! PAVIMENTO Por RUTA 15	47,41	
21,97	0,08				47,33	
22,35	0,38			VILLA DE SOTO 22 CRUZ DEL EJE 55 SERREZUELA 78	46,95	
33,13	10,78			TRES ARBOLES	36,17	
42,45	9,32				26,85	
43,86	1,41			i ! TIERRA	25,44	

LPE	3/6	RUMI HUASI	PAGINA	20		
CH	3a	CRUZ DEL EJE - ZONA TECNICA - INGRESO	ETAPA	1/2		
	6a	CRUZ DEL EJE - PARQUE CERRADO - INGRESO	SECCION	1/2		
PRUEBAS ESPECIALES		RUMI HUASI - RARA FORTUNA				
3/6		DISTANCIA PE	ENLACE	DISTANCIA TOTAL	TIEMPO OTORGADO	PROMEDIO
		18,27	51,03	69,30	1:15	55,44
DISTANCIA		DIRECCION		INFORMACION	DISTANCIA REGRESIVA	
TOTAL	PARCIAL					
44,13	0,27			i ! PAVIMENTO !! RUTA 38 (1) Hacia LPE 1	25,17	
44,23	0,10			RIO SOTO	25,07	
45,48	1,25			AXION	23,82	
66,01	20,53			!! CRUCE RUTA	3,29	
66,83	0,82				2,47	
67,13	0,30				2,17	



LPE	3/6 RUMI HUASI		PAGINA 21			
	CH	3a CRUZ DEL EJE - ZONA TECNICA - INGRESO 6a CRUZ DEL EJE - PARQUE CERRADO - INGRESO	ETAPA 1/2			
PRUEBAS ESPECIALES		RUMI HUASI - RARA FORTUNA			SECCION 1/2	
3/6		DISTANCIA PE	ENLACE	DISTANCIA TOTAL	TIEMPO OTORGADO	PROMEDIO
		18,27	51,03	69,30	1:15	55,44
DISTANCIA		DIRECCION		INFORMACION	DISTANCIA REGRESIVA	
TOTAL	PARCIAL					
67,23	0,10	31				2,07
67,33	0,10	32				1,97
67,42	0,09	33				1,88
67,64	0,22	34				1,66
67,69	0,05	35				1,61
68,16	0,47	36				1,14



LPE	3/6 RUMI HUASI		PAGINA 22			
	CH	3a CRUZ DEL EJE - ZONA TECNICA - INGRESO 6a CRUZ DEL EJE - PARQUE CERRADO - INGRESO	ETAPA 1/2			
PRUEBAS ESPECIALES		RUMI HUASI - RARA FORTUNA			SECCION 1/2	
3/6		DISTANCIA PE	ENLACE	DISTANCIA TOTAL	TIEMPO OTORGADO	PROMEDIO
		18,27	51,03	69,30	1:15	55,44
DISTANCIA		DIRECCION		INFORMACION	DISTANCIA REGRESIVA	
TOTAL	PARCIAL					
68,27	0,11	37		<i>i</i> ! TIERRA		1,03
68,48	0,21	38		<i>i</i> ! PAVIMENTO Por Gral. Paz		0,82
68,58	0,10	39				0,72
68,69	0,11	40				0,61
68,87	0,18	41				0,43
68,95	0,08	42				0,35



LPE	3/6	RUMI HUASI	PAGINA		23																	
	CH	3a	CRUZ DEL EJE - ZONA TECNICA - INGRESO	ETAPA		1/2																
		6a	CRUZ DEL EJE - PARQUE CERRADO - INGRESO	SECCION		1/2																
PRUEBAS ESPECIALES		RUMI HUASI - RARA FORTUNA																				
3/6		DISTANCIA PE	ENLACE	DISTANCIA TOTAL	TIEMPO OTORGADO	PROMEDIO																
		18,27	51,03	69,30	1:15	55,44																
DISTANCIA		DIRECCION		INFORMACION		DISTANCIA REGRESIVA																
TOTAL	PARCIAL																					
69,07	0,12					0,23																
69,18	0,11					0,12																
69,24	0,06					0,06																
69,30	0,06			<table border="1"> <tr> <td colspan="4">PASO 1° AUTO</td> </tr> <tr> <td>HORA</td> <td>3a</td> <td>10:51</td> <td>6a</td> <td>18:51</td> <td>HORA</td> </tr> <tr> <td colspan="6">CH (30 43.1658/64 48.354w) Alt.: 472</td> </tr> </table> <p>i ! TIERRA PREDIO DEL OLIVO CH 3a - Ingreso Zona Técnica CH 6a - Ingreso Parque Cerrado</p>		PASO 1° AUTO				HORA	3a	10:51	6a	18:51	HORA	CH (30 43.1658/64 48.354w) Alt.: 472						0,00
PASO 1° AUTO																						
HORA	3a	10:51	6a	18:51	HORA																	
CH (30 43.1658/64 48.354w) Alt.: 472																						
<p>VOLVER A PAGINA 1 PARA COMENZAR CON LA SECCION 2</p>																						



2da Fecha

1 y 2 etapa



CH		0 CRUZ DEL EJE - PARQUE DE SERVICIOS - SALIDA				PAGINA
CH		1 SUPER ESPECIAL AERO CLUB CRUZ DEL EJE				25
PRUEBAS ESPECIALES						ETAPA
						1
						SECCION
						1
		DISTANCIA PE	ENLACE	DISTANCIA TOTAL	TIEMPO OTORGADO	PROMEDIO
			3,43	3,43	0:15	13,72
DISTANCIA		DIRECCION		INFORMACION		DISTANCIA REGRESIVA
TOTAL	PARCIAL					
0,00	0,00			 PASO 1° AUTO HORA 0 16:45 HORA - (30 43.236s/64 48.333w) Alt.: 464 PREDIO DEL OLIVO CH 0 - Salida Parque de Servicios		3,43
				(1) Reabastecimiento		
0,10	0,10					3,33
0,15	0,05			Por San Martín		3,28
0,28	0,13					3,15
0,36	0,08					3,07
0,45	0,09			Por L. N. Alem		2,98

CH		0 CRUZ DEL EJE - PARQUE DE SERVICIOS - SALIDA				PAGINA
CH		1 SUPER ESPECIAL AERO CLUB CRUZ DEL EJE				26
PRUEBAS ESPECIALES						ETAPA
						1
						SECCION
						1
		DISTANCIA PE	ENLACE	DISTANCIA TOTAL	TIEMPO OTORGADO	PROMEDIO
			3,43	3,43	0:15	13,72
DISTANCIA		DIRECCION		INFORMACION		DISTANCIA REGRESIVA
TOTAL	PARCIAL					
0,72	0,27			Por José Hernández		2,71
1,85	1,13			 CRUCE RUTA 16		1,58
2,54	0,69			 TIERRA		0,89
3,30	0,76					0,13
3,43	0,13	 LARGADA: +0,11		 PASO 1° AUTO HORA 1 17:00 HORA - (30 42.536s/64 47.520w) Alt.: 500 En poste alambrado pintado con letra "M"		0,00

LPE	1	1	SUPER ESPECIAL AERO CLUB CRUZ DEL EJE	PAGINA	27	
CH	1a	1	CRUZ DEL EJE - PARQUE CERRADO - INGRESO	ETAPA	1	
PRUEBAS ESPECIALES		SUPER ESPECIAL AERO CLUB CRUZ DEL EJE			SECCION	1
1		DISTANCIA PE	ENLACE	DISTANCIA TOTAL	TIEMPO OTORGADO	PROMEDIO
		2,30	4,63	6,93	0:20	20,79

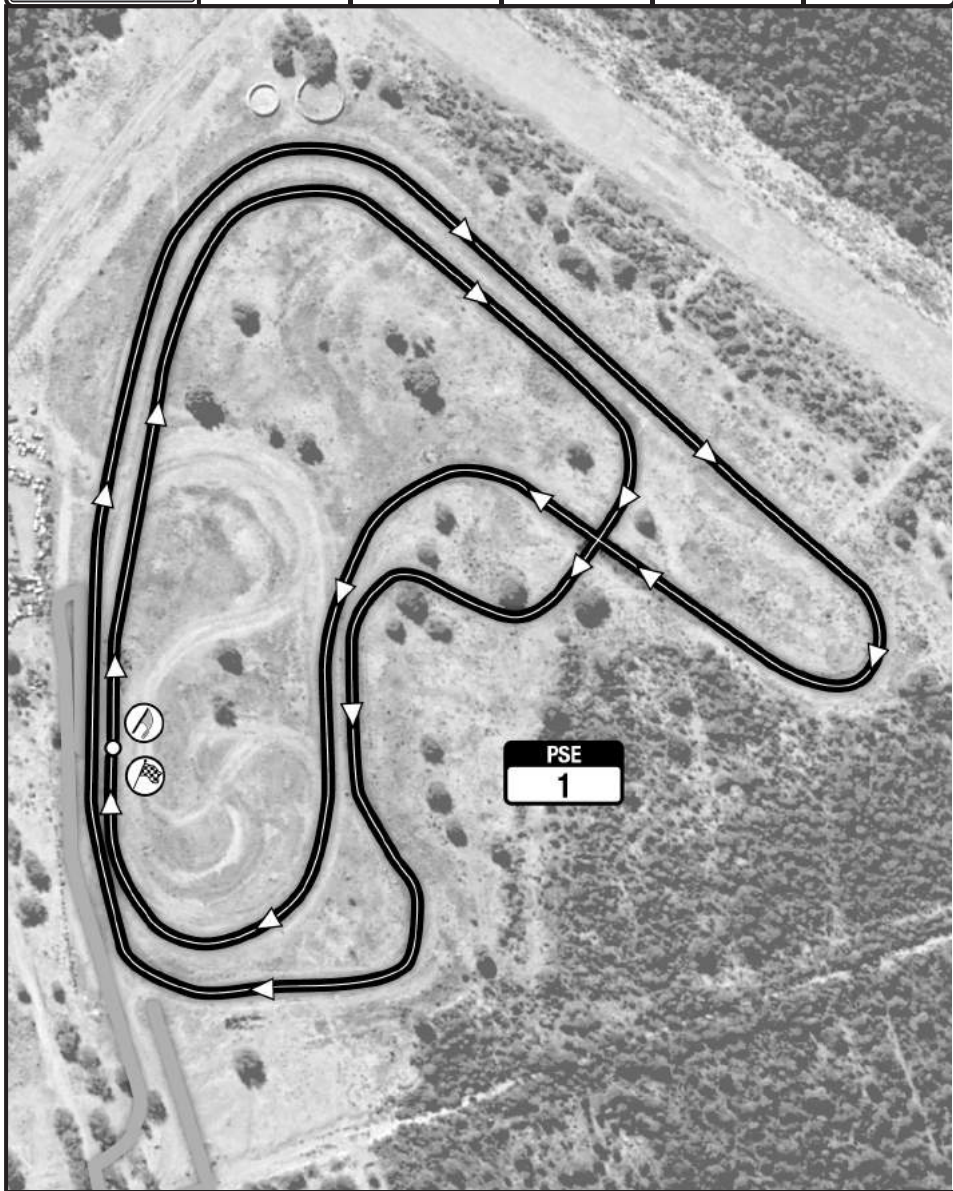



LPE	1	1	SUPER ESPECIAL AERO CLUB CRUZ DEL EJE	PAGINA	28	
CH	1a	1	CRUZ DEL EJE - PARQUE CERRADO - INGRESO	ETAPA	1	
PRUEBAS ESPECIALES		SUPER ESPECIAL AERO CLUB CRUZ DEL EJE			SECCION	1
1		DISTANCIA PE	ENLACE	DISTANCIA TOTAL	TIEMPO OTORGADO	PROMEDIO
		2,30	4,63	6,93	0:20	20,79

DISTANCIA		DIRECCION	INFORMACION	DISTANCIA REGRESIVA
TOTAL	PARCIAL			
0,00	0,00		PASO 1° AUTO HORA: 1 17:03 - - LPE (30 42.484s/64 47.448w) Alt.: 499 En poste eléctrico pintado con letra "B"	6,93
2,30	2,30		FPE 1 - (30 42.484s/64 47.448w) Alt.: 499 En poste eléctrico pintado con letra "B"	4,63
2,40	0,10			4,53
2,71	0,31		STOP G.P.S. (30 42.528s / 64 47.530w)	4,22
2,78	0,07		Salida PREDIO AERO CLUB	4,15
3,53	0,75		i ! PAVIMENTO	3,40

LPE	1	SUPER ESPECIAL AERO CLUB CRUZ DEL EJE				PAGINA 29
CH	1a	CRUZ DEL EJE - PARQUE CERRADO - INGRESO				ETAPA 1
PRUEBAS ESPECIALES		SUPER ESPECIAL AERO CLUB CRUZ DEL EJE				SECCION 1
1		DISTANCIA PE 2,30	ENLACE 4,63	DISTANCIA TOTAL 6,93	TIEMPO OTORGADO 0:20	PROMEDIO 20,79
DISTANCIA		DIRECCION		INFORMACION	DISTANCIA REGRESIVA	
TOTAL	PARCIAL					
4,15	0,62				2,78	
4,39	0,24				2,54	
5,00	0,61				1,93	
5,26	0,26			 Por L. N. ALEM	1,67	
6,61	1,35			Por R D Moyano	0,32	
6,93	0,32			 PASO 1° AUTO CH 1a 17:23 - - (30 44.083s/64 47.407w) Alt.: 475 TIERRA CH 1a - Ingreso Parque Cerrado	0,00	

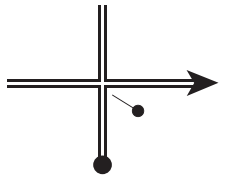
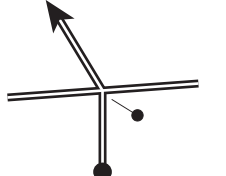
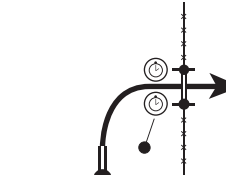
CH	1b	CRUZ DEL EJE - PARQUE CERRADO - SALIDA				PAGINA 30
CH	1c	CRUZ DEL EJE - PARQUE DE SERVICIOS - INGRESO				ETAPA 1
PRUEBAS ESPECIALES						SECCION 2
		DISTANCIA PE 2,95	ENLACE 2,95	DISTANCIA TOTAL 2,95	TIEMPO OTORGADO 0:10	PROMEDIO 17,70
DISTANCIA		DIRECCION		INFORMACION	DISTANCIA REGRESIVA	
TOTAL	PARCIAL					
0,00	0,00			 PASO 1° AUTO CH 1b 6:50 - - (30 44.083s/64 47.407w) Alt.: 475 PAVIMENTO CH 1b - Salida Parque Cerrado	2,95	
0,10	0,10			Por L. N. ALEM	2,85	
1,70	1,60			Por G. Luna	1,25	
1,79	0,09			Por Rivadavia	1,16	
2,00	0,21			Por Alvear	0,95	
2,09	0,09				0,86	

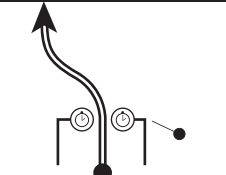
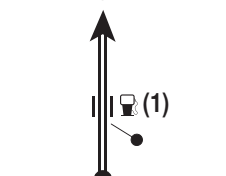
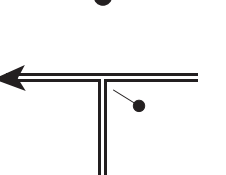
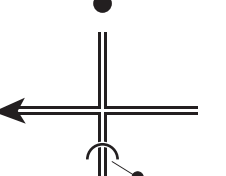
CH	1b	CRUZ DEL EJE - PARQUE CERRADO - SALIDA	PAGINA	31													
	1c	CRUZ DEL EJE - PARQUE DE SERVICIOS - INGRESO	ETAPA	1													
PRUEBAS ESPECIALES			SECCION	2													
DISTANCIA PE		ENLACE	DISTANCIA TOTAL	TIEMPO OTORGADO	PROMEDIO												
		2,95	2,95	0:10	17,70												
DISTANCIA		DIRECCION	INFORMACION	DISTANCIA REGRESIVA													
TOTAL	PARCIAL																
2,81	0,72		Por Gral. Paz	0,14													
2,86	0,05			0,09													
2,95	0,09		<table border="1"> <tr> <th colspan="4">PASO 1° AUTO</th> </tr> <tr> <td>CH</td> <td>1c</td> <td>7:00</td> <td>-</td> </tr> <tr> <td colspan="4">(30 43.165s/64 48.354w) Alt.: 472</td> </tr> </table> <p>TIERRA PREDIO DEL OLIVO CH 1c - Ingreso Parque de servicio</p>	PASO 1° AUTO				CH	1c	7:00	-	(30 43.165s/64 48.354w) Alt.: 472				0,00	
PASO 1° AUTO																	
CH	1c	7:00	-														
(30 43.165s/64 48.354w) Alt.: 472																	

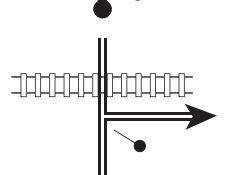
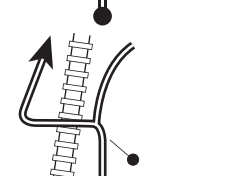



CH	1d	CRUZ DEL EJE - PARQUE DE SERVICIOS - SALIDA	PAGINA	32													
	4e	CRUZ DEL EJE - REAGRUPAMIENTO - SALIDA	ETAPA	1/2													
CH	2/5	RUMI HUASI	SECCION	2/3													
	PRUEBAS ESPECIALES																
DISTANCIA PE		ENLACE	DISTANCIA TOTAL	TIEMPO OTORGADO	PROMEDIO												
		61,52	61,52	1:10	52,73												
DISTANCIA		DIRECCION	INFORMACION	DISTANCIA REGRESIVA													
TOTAL	PARCIAL																
0,00	0,00		<table border="1"> <tr> <th colspan="4">PASO 1° AUTO</th> </tr> <tr> <td>CH</td> <td>1d</td> <td>7:25</td> <td>4e 13:00</td> </tr> <tr> <td colspan="4">(30 43.236s/64 48.333w) Alt.: 464</td> </tr> </table> <p>PREDIO DEL OLIVO CH 1d - Salida Parque de Servicios CH 4e - Salida Reagrupamiento</p>	PASO 1° AUTO				CH	1d	7:25	4e 13:00	(30 43.236s/64 48.333w) Alt.: 464				61,52	
PASO 1° AUTO																	
CH	1d	7:25	4e 13:00														
(30 43.236s/64 48.333w) Alt.: 464																	
0,10	0,10		(1) Reabastecimiento	61,42													
0,15	0,05		Por San Martín	61,37													
0,28	0,13			61,24													
0,36	0,08			61,16													
0,45	0,09		Por L. N. Alem	61,07													



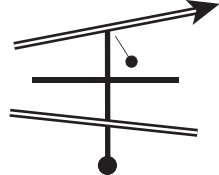
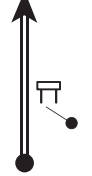

CH	1d		4e		PAGINA
	CRUZ DEL EJE - PARQUE DE SERVICIOS - SALIDA		CRUZ DEL EJE - REAGRUPAMIENTO - SALIDA		33
CH	2/5		RUMI HUASI		ETAPA
					1/2
PRUEBAS ESPECIALES					SECCION
					2/3
DISTANCIA PE		ENLACE	DISTANCIA TOTAL	TIEMPO OTORGADO	PROMEDIO
		61,52	61,52	1:10	52,73
DISTANCIA		DIRECCION	INFORMACION	DISTANCIA REGRESIVA	
TOTAL	PARCIAL				
0,72	0,27			60,80	
0,98	0,26			60,54	
1,51	0,53			60,01	
2,01	0,50			59,51	
2,48	0,47			59,04	
2,71	0,23		Por Av. Eva Perón	58,81	

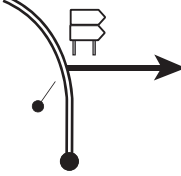

CH	1d		4e		PAGINA
	CRUZ DEL EJE - PARQUE DE SERVICIOS - SALIDA		CRUZ DEL EJE - REAGRUPAMIENTO - SALIDA		34
CH	2/5		RUMI HUASI		ETAPA
					1/2
PRUEBAS ESPECIALES					SECCION
					2/3
DISTANCIA PE		ENLACE	DISTANCIA TOTAL	TIEMPO OTORGADO	PROMEDIO
		61,52	61,52	1:10	52,73
DISTANCIA		DIRECCION	INFORMACION	DISTANCIA REGRESIVA	
TOTAL	PARCIAL				
2,85	0,14		YPF (1) Reabastecimiento Rally Cordobés Por RUTA	58,67	
3,04	0,19			58,48	
3,44	0,40			58,08	
24,05	20,61		AXION	37,47	
25,17	1,12		RIO SOTO	36,35	
25,43	0,26		TIERRA CRUCE RUTA	36,09	

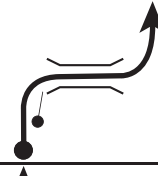

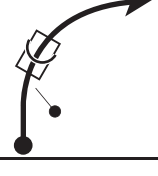
CH	1d		CRUZ DEL EJE - PARQUE DE SERVICIOS - SALIDA		PAGINA
	4e		CRUZ DEL EJE - REAGRUPAMIENTO - SALIDA		35
CH	2/5		RUMI HUASI		ETAPA
					1/2
PRUEBAS ESPECIALES					SECCION
					2/3
DISTANCIA PE		ENLACE	DISTANCIA TOTAL	TIEMPO OTORGADO	PROMEDIO
		61,52	61,52	1:10	52,73
DISTANCIA		DIRECCION	INFORMACION	DISTANCIA REGRESIVA	
TOTAL	PARCIAL				
25,62	0,19		i ! PAVIMENTO Por RUTA 15	35,90	
35,58	9,96		TRES ARBOLES	25,94	
47,43	11,85		LA HIGUERA	14,09	
47,66	0,23		i ! TIERRA CIENAGA DEL CORO GUASAPAMPA LA PLAYA TOSNO	13,86	
47,78	0,12			13,74	
47,95	0,17			13,57	

CH	1d		CRUZ DEL EJE - PARQUE DE SERVICIOS - SALIDA		PAGINA
	4e		CRUZ DEL EJE - REAGRUPAMIENTO - SALIDA		36
CH	2/5		RUMI HUASI		ETAPA
					1/2
PRUEBAS ESPECIALES					SECCION
					2/3
DISTANCIA PE		ENLACE	DISTANCIA TOTAL	TIEMPO OTORGADO	PROMEDIO
		61,52	61,52	1:10	52,73
DISTANCIA		DIRECCION	INFORMACION	DISTANCIA REGRESIVA	
TOTAL	PARCIAL				
49,18	1,23			12,34	
49,65	0,47			11,87	
50,93	1,28			10,59	
53,44	2,51			8,08	
53,83	0,39			7,69	
56,94	3,11			4,58	

CH	1d	CRUZ DEL EJE - PARQUE DE SERVICIOS - SALIDA	PAGINA	37		
	4e	CRUZ DEL EJE - REAGRUPAMIENTO - SALIDA	ETAPA	1/2		
CH	2/5	RUMI HUASI	SECCION	2/3		
PRUEBAS ESPECIALES		DISTANCIA PE	ENLACE	DISTANCIA TOTAL	TIEMPO OTORGADO	PROMEDIO
			61,52	61,52	1:10	52,73
DISTANCIA		DIRECCION		INFORMACION		DISTANCIA REGRESIVA
TOTAL	PARCIAL					
57,22	0,28					4,30
60,13	2,91			RUMI HUASI		1,39
60,57	0,44			(1) Parador Colectivo		0,95
61,35	0,78			CIENAGA DEL CORO 9 → ← ESTANCIA DE GUADALUPE 12 TOSNO 13 → GUASAPAMPA 20 → LA PLAYA 28 →		0,17
61,52	0,17			PASO 1º AUTO CH 2 8:35 5 14:10 31 02.491s/65 13.327w Alt.: 776 En Tanque de Agua		0,00

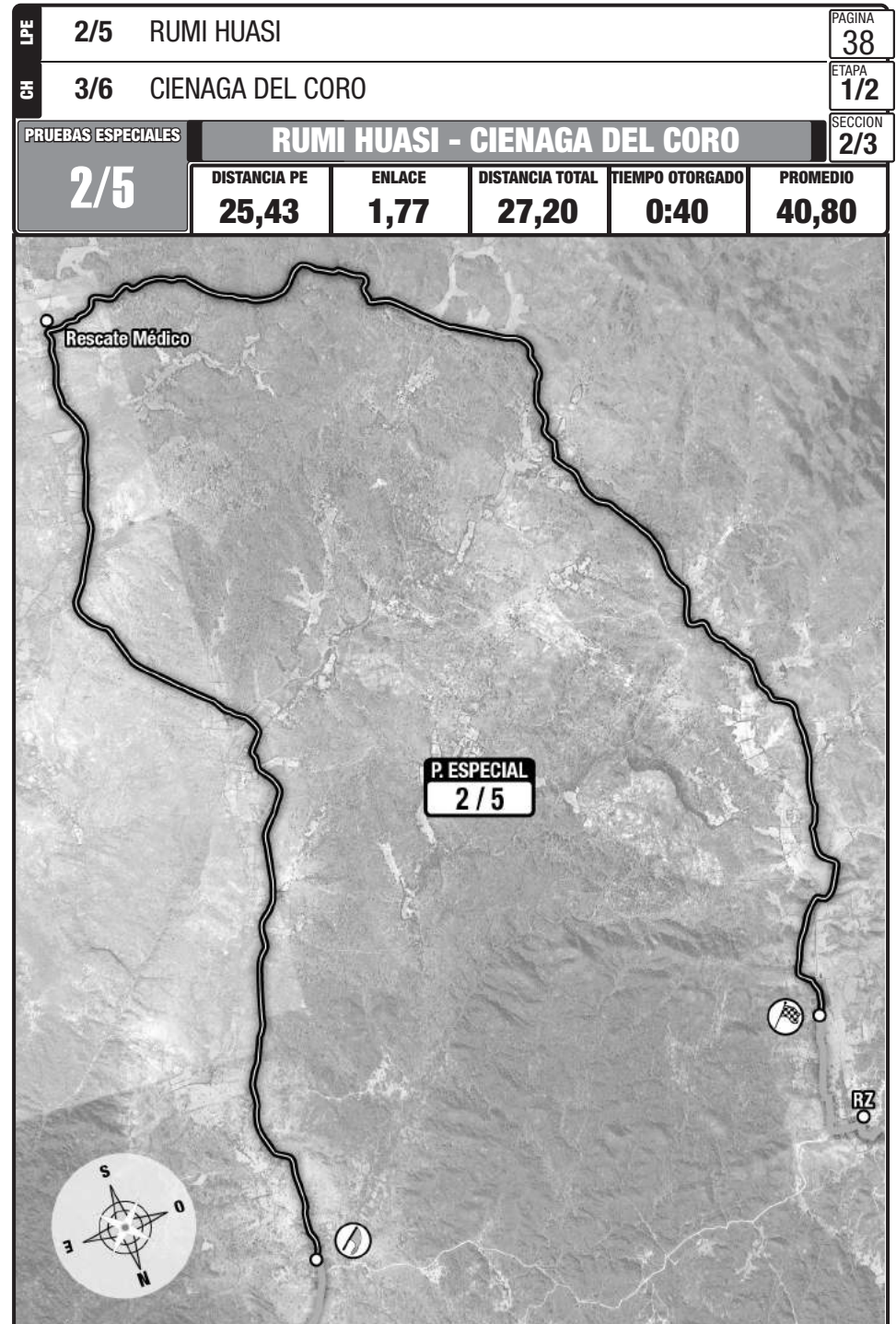

LPE	2/5	RUMI HUASI	PAGINA		39	
CH	3/6	CIENAGA DEL CORO	ETAPA		1/2	
PRUEBAS ESPECIALES		RUMI HUASI - CIENAGA DEL CORO			SECCION	2/3
2/5		DISTANCIA PE	ENLACE	DISTANCIA TOTAL	TIEMPO OTORGADO	PROMEDIO
25,43		1,77	27,20	0:40	40,80	
DISTANCIA		DIRECCION		INFORMACION		DISTANCIA REGRESIVA
TOTAL	PARCIAL					
0,00	0,00			 PASO 1° AUTO 2 8:38 5 14:13 <small>31 02.510s/65 13.330w Alt.: 777</small> En piedra pintada con letra "B"		27,20
0,23	0,23					26,97
1,66	1,43					25,54
8,21	6,55					18,99
9,57	1,36					17,63
10,03	0,46					17,17

LPE	2/5	RUMI HUASI	PAGINA		40	
CH	3/6	CIENAGA DEL CORO	ETAPA		1/2	
PRUEBAS ESPECIALES		RUMI HUASI - CIENAGA DEL CORO			SECCION	2/3
2/5		DISTANCIA PE	ENLACE	DISTANCIA TOTAL	TIEMPO OTORGADO	PROMEDIO
25,43		1,77	27,20	0:40	40,80	
DISTANCIA		DIRECCION		INFORMACION		DISTANCIA REGRESIVA
TOTAL	PARCIAL					
10,96	0,93					16,24
11,12	0,16			 GPS: 31 07.830s 65 13.289w		16,08
13,94	2,82					13,26
18,11	4,17					9,09
22,69	4,58					4,51
25,43	2,74			 2 5 <small>31 03.076s/65 16.864w Alt.: 964</small> En poste alambrado pintado con letra "B"		1,77

LPE	2/5	RUMI HUASI	PAGINA		41		
	CH	3/6	CIENAGA DEL CORO	ETAPA		1/2	
PRUEBAS ESPECIALES		RUMI HUASI - CIENAGA DEL CORO			SECCION		2/3
2/5		DISTANCIA PE	ENLACE	DISTANCIA TOTAL	TIEMPO OTORGADO	PROMEDIO	
		25,43	1,77	27,20	0:40	40,80	
DISTANCIA		DIRECCION		INFORMACION		DISTANCIA REGRESIVA	
TOTAL	PARCIAL						
25,92	0,49			STOP G.P.S. 31 02.821s / 65 16.788w En poste alambrado pintado con letra "M"		1,28	
26,53	0,61					0,67	
26,65	0,12					0,55	
26,97	0,32					0,23	
27,01	0,04			(1) Reabastecimiento G.P.S. 31 02.394s / 65 16.933w		0,19	
27,05	0,04					0,15	



LPE	2/5	RUMI HUASI	PAGINA		42		
	CH	3/6	CIENAGA DEL CORO	ETAPA		1/2	
PRUEBAS ESPECIALES		RUMI HUASI - CIENAGA DEL CORO			SECCION		2/3
2/5		DISTANCIA PE	ENLACE	DISTANCIA TOTAL	TIEMPO OTORGADO	PROMEDIO	
		25,43	1,77	27,20	0:40	40,80	
DISTANCIA		DIRECCION		INFORMACION		DISTANCIA REGRESIVA	
TOTAL	PARCIAL						
27,20	0,15			PASO 1° AUTO CH 3 9:18 6 14:53 31 02.369s/65 17.003w Alt.: 942 En Poste de electricidad pintado con letra "M"		0,00	

LPE	3/6 CIENAGA DEL CORO	PAGINA	43
CH	4/7 TOSNO	ETAPA	1/2
PRUEBAS ESPECIALES		CIENAGA DEL CORO - TOSNO	
3/6		DISTANCIA PE	10,42
		ENLACE	1,28
		DISTANCIA TOTAL	11,70
		TIEMPO OTORGADO	0:20
		PROMEDIO	35,10







LPE	3/6 CIENAGA DEL CORO	PAGINA	44
CH	4/7 TOSNO	ETAPA	1/2
PRUEBAS ESPECIALES		CIENAGA DEL CORO - TOSNO	
3/6		DISTANCIA PE	10,42
		ENLACE	1,28
		DISTANCIA TOTAL	11,70
		TIEMPO OTORGADO	0:20
		PROMEDIO	35,10
DISTANCIA		DIRECCION	
TOTAL	PARCIAL	INFORMACION	
0,00	0,00	 PASO 1° AUTO HORA 3 9:21 HORA 6 14:56 <small>(31 02.369s/65 17.025w) Alt.: 941</small> En árbol pintado con letra "B"	
0,43	0,43	 !!	
2,51	2,08	 !!	
6,75	4,24	 Comuna Tosno	
10,29	3,54	 FPE 3 6 <small>(30 57.586s/65 18.647w) Alt.: 1057</small>	
10,42	0,13	 En cruce	
		DISTANCIA REGRESIVA	
		11,70	
		11,27	
		9,19	
		4,95	
		1,41	
		1,28	



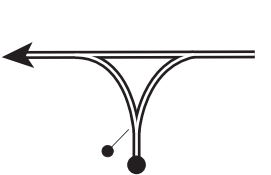
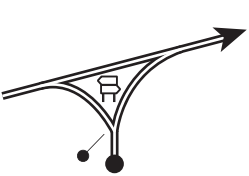

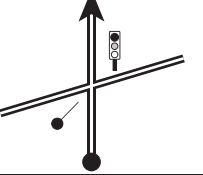
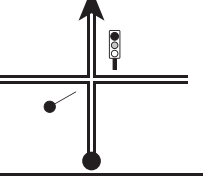
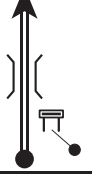

LPE	3/6	CIENAGA DEL CORO			PAGINA	45	
	CH	4/7	TOSNO			ETAPA	1/2
PRUEBAS ESPECIALES		CIENAGA DEL CORO - TOSNO				SECCION	2/3
3/6		DISTANCIA PE	ENLACE	DISTANCIA TOTAL	TIEMPO OTORGADO	PROMEDIO	
		10,42	1,28	11,70	0:20	35,10	
DISTANCIA		DIRECCION		INFORMACION	DISTANCIA REGRESIVA		
TOTAL	PARCIAL						
10,67	0,25			STOP G.P.S. (30 57.488s / 65 18.724w) En árbol pintado con letra "M"	1,03		
11,70	1,03			PASO 1° AUTO HORA HORA HORA HORA 4 9:41 7 15:16 CH (30 57.012s/65 18.950w) Alt.: 1045 En árbol pintado con letra "M"	0,00		

LPE	4/7	TOSNO			PAGINA	46	
	CH	4a	CRUZ DEL EJE - ZONA TECNICA - INGRESO			ETAPA	1/2
PRUEBAS ESPECIALES		TOSNO - SANTA ANA				SECCION	2/3
4/7		DISTANCIA PE	ENLACE	DISTANCIA TOTAL	TIEMPO OTORGADO	PROMEDIO	
		19,61	54,92	74,53	1:10	63,88	

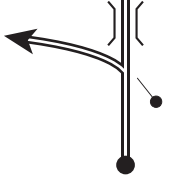
LPE	4/7	TOSNO	PAGINA			47			
	CH	4a	CRUZ DEL EJE - ZONA TECNICA - INGRESO			ETAPA	1/2		
		7a	CRUZ DEL EJE - PARQUE CERRADO - INGRESO			SECCION	2/3		
PRUEBAS ESPECIALES		TOSNO - SANTA ANA				4/7			
DISTANCIA PE		ENLACE		DISTANCIA TOTAL		TIEMPO OTORGADO		PROMEDIO	
19,61		54,92		74,53		1:10		63,88	
DISTANCIA		DIRECCION		INFORMACION		DISTANCIA REGRESIVA			
TOTAL	PARCIAL								
0,00	0,00					74,53			
3,26	3,26					71,27			
5,32	2,06					69,21			
15,00	9,68					59,53			
15,68	0,68					58,85			
19,61	3,93					54,92			

LPE	4/7	TOSNO	PAGINA			48			
	CH	4a	CRUZ DEL EJE - ZONA TECNICA - INGRESO			ETAPA	1/2		
		7a	CRUZ DEL EJE - PARQUE CERRADO - INGRESO			SECCION	2/3		
PRUEBAS ESPECIALES		TOSNO - SANTA ANA				4/7			
DISTANCIA PE		ENLACE		DISTANCIA TOTAL		TIEMPO OTORGADO		PROMEDIO	
19,61		54,92		74,53		1:10		63,88	
DISTANCIA		DIRECCION		INFORMACION		DISTANCIA REGRESIVA			
TOTAL	PARCIAL								
20,07	0,46					54,46			
24,48	4,41					50,05			
28,03	3,55					46,50			
28,51	0,48					46,02			
28,82	0,31					45,71			
29,26	0,44					45,27			

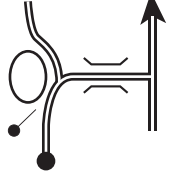
LPE	4/7	TOSNO	PAGINA		49	
	CH	4a	CRUZ DEL EJE - ZONA TECNICA - INGRESO		ETAPA	1/2
		7a	CRUZ DEL EJE - PARQUE CERRADO - INGRESO		SECCION	2/3
PRUEBAS ESPECIALES		TOSNO - SANTA ANA				
4/7		DISTANCIA PE	ENLACE	DISTANCIA TOTAL	TIEMPO OTORGADO	PROMEDIO
		19,61	54,92	74,53	1:10	63,88
DISTANCIA		DIRECCION		INFORMACION	DISTANCIA REGRESIVA	
TOTAL	PARCIAL					
30,34	1,08				44,19	
36,16	5,82			!! RUTA 38  	38,37	
47,21	11,05				27,32	
48,16	0,95				26,37	
49,46	1,30				25,07	
50,71	1,25				23,82	

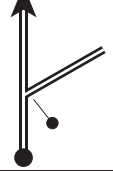
LPE	4/7	TOSNO	PAGINA		50	
	CH	4a	CRUZ DEL EJE - ZONA TECNICA - INGRESO		ETAPA	1/2
		7a	CRUZ DEL EJE - PARQUE CERRADO - INGRESO		SECCION	2/3
PRUEBAS ESPECIALES		TOSNO - SANTA ANA				
4/7		DISTANCIA PE	ENLACE	DISTANCIA TOTAL	TIEMPO OTORGADO	PROMEDIO
		19,61	54,92	74,53	1:10	63,88
DISTANCIA		DIRECCION		INFORMACION	DISTANCIA REGRESIVA	
TOTAL	PARCIAL					
71,24	20,53			!! CRUCE RUTA	3,29	
72,06	0,82				2,47	
72,36	0,30				2,17	
72,46	0,10				2,07	
72,56	0,10				1,97	
72,65	0,09				1,88	

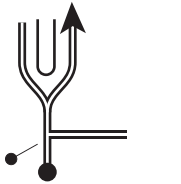
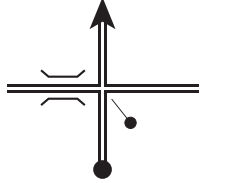
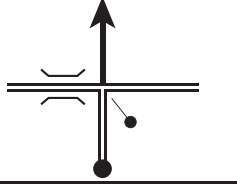
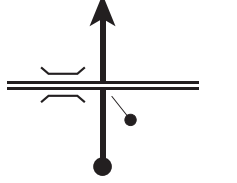
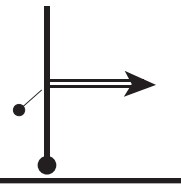
LPE	4/7	TOSNO	PAGINA		51	
	CH	4a	CRUZ DEL EJE - ZONA TECNICA - INGRESO	ETAPA		1/2
		7a	CRUZ DEL EJE - PARQUE CERRADO - INGRESO	SECCION		2/3
PRUEBAS ESPECIALES			TOSNO - SANTA ANA			
4/7		DISTANCIA PE	ENLACE	DISTANCIA TOTAL	TIEMPO OTORGADO	PROMEDIO
		19,61	54,92	74,53	1:10	63,88
DISTANCIA		DIRECCION		INFORMACION	DISTANCIA REGRESIVA	
TOTAL	PARCIAL					
72,87	0,22				1,66	
72,92	0,05				1,61	
73,39	0,47				1,14	
73,50	0,11			<i>i</i> ! TIERRA	1,03	
73,71	0,21				0,82	
73,81	0,10			<i>i</i> ! PAVIMENTO Por Gral. Paz	0,72	

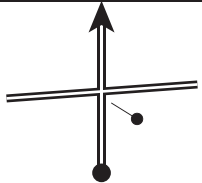
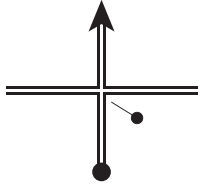
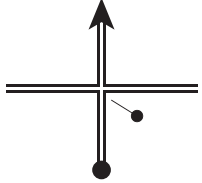
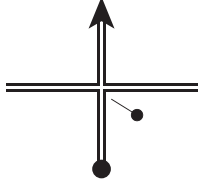
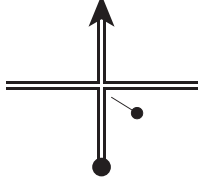
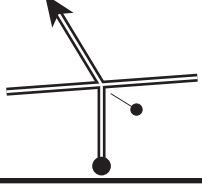

LPE	4/7	TOSNO	PAGINA		52	
	CH	4a	CRUZ DEL EJE - ZONA TECNICA - INGRESO	ETAPA		1/2
		7a	CRUZ DEL EJE - PARQUE CERRADO - INGRESO	SECCION		2/3
PRUEBAS ESPECIALES			TOSNO - SANTA ANA			
4/7		DISTANCIA PE	ENLACE	DISTANCIA TOTAL	TIEMPO OTORGADO	PROMEDIO
		19,61	54,92	74,53	1:10	63,88
DISTANCIA		DIRECCION		INFORMACION	DISTANCIA REGRESIVA	
TOTAL	PARCIAL					
73,92	0,11				0,61	
74,10	0,18				0,43	
74,18	0,08				0,35	
74,30	0,12				0,23	
74,41	0,11				0,12	
74,47	0,06				0,06	



LPE	4/7 TOSNO				PAGINA	53											
	CH	4a	CRUZ DEL EJE - ZONA TECNICA - INGRESO			ETAPA	1/2										
7a		CRUZ DEL EJE - PARQUE CERRADO - INGRESO			SECCION	2/3											
PRUEBAS ESPECIALES		TOSNO - SANTA ANA															
4/7		DISTANCIA PE	ENLACE	DISTANCIA TOTAL	TIEMPO OTORGADO	PROMEDIO											
		19,61	54,92	74,53	1:10	63,88											
DISTANCIA		DIRECCION		INFORMACION		DISTANCIA REGRESIVA											
TOTAL	PARCIAL																
74,53	0,06			PASO 1° AUTO <table border="1"> <tr> <td>CH</td> <td>4a</td> <td>10:54</td> <td>7a</td> <td>16:29</td> </tr> <tr> <td></td> <td colspan="2">30 43.165s/64 48.354w</td> <td colspan="2">Alt.: 472</td> </tr> </table>		CH	4a	10:54	7a	16:29		30 43.165s/64 48.354w		Alt.: 472		0,00	
CH	4a	10:54	7a	16:29													
	30 43.165s/64 48.354w		Alt.: 472														
<p>i ! TIERRA PREDIO DEL OLIVO CH 4a - Ingreso Zona Técnica CH 7a - Ingreso Parque Cerrado</p>																	
<p>VOLVER A PAGINA 32 PARA COMENZAR CON LA SECCION 3</p>																	